

I-HIPB5PI-MF



5 MP IP IR Fixed Bullet Camera

The I-HIPB5PI-MF is a 5MP IP IR Fixed Bullet Camera designed for high-resolution surveillance. It offers advanced features such as Smart IR for night vision up to 30 meters, triple-stream capability, built-in microphone, and SD card slot for local storage. The camera provides flexible connectivity options, robust security measures, and operates in extreme temperatures. Its compact design makes it suitable for discreet outdoor installations.



FEATURES AND BENEFITS



**Up to 2592x1944
@30fps**



**IR Distance Up
to 30 Mts**



Metal



**Slot up to
256GB**



Built-in-mic



**H.265+/H.265/H.264
Video Compressions**



IP67



**Min. illumination Color
0.003lux @ F1.6**

SPECIFICATIONS

VIDEO	
Imaging Device	1/2.7"
Effective Pixels	5MP 2592(H)×1944(V)
Scanning System	Progressive CMOS
Min. Illumination	Color 0.003lux @ F1.6(AGC ON); B/W 0 lux @ IR ON
LENS TYPE	
Focal Length (Zoom Ratio)	3.6mm
Max. Aperture Ratio	F No. 1.6
Angular Field of View	Horizontal: 79°, Vertical: 56°, Diagonal: 106°
Min. Object Distance	2m
Lens Type	Fixed(M12)
DORI	(3.6mm) D-72.0m, O-28.8m, R-14.4m, I-7.2m

OPERATIONAL	
IR Viewable Length	Up to 30m
Camera Title	On/Off
Day & Night	IR cut filter with auto switch (Day/Night/Auto/Image/Schedule)
Backlight Compensation	Off/On (5 Zone)
Wide Dynamic Range	True WDR
Digital Noise Reduction	3D DNR
Motion Detection	Off/On (8 Level)
Privacy Masking	Off/On (4 Zone, Rectangle)
Gain Control	Auto
White Balance	Auto / Manual
Electronic Shutter Speed	1/5 ~ 1/20000s
On-Board Storage	Micro SD slot, up to 256GB
Audio	Built-in microphone
Hardware Reset	Yes
Smart Feature	Face Recognition (FR), Human & Vehicle Detection (PD & VD), Perimeter Intrusion Detection (PID), Line Crossing Detection (LCD), Cross Counting (CC), Stationary Object Detection (SOD), Heat Map (HM), Crowd Density Detection (CD), Queue Length Detection (QD), Rare Sound Detection (RSD)

NETWORK	
Ethernet	RJ45(10/100BASE-T)
Video Compression Format	H.265+/H.265/H.264
Resolution	Main Stream @30fps 5MP (2592x1944), 4MP (2592x1520), 3MP (2304x1296), 1080P (1920x1080), 960P (1280*960) Sub Stream @30fps 1080P (1920x1080), 720P (1280x720), VGA (640x480) Third Stream @30fps VGA (640x480), QVGA (320x240)
Video Quality Adjustment	256Kbps ~ 8Mbps
Bitrate control method	CBR/VBR
Streaming Capability	Triple-Stream(Main/Sub/Third)
Protocol	TCP/IP, HTTP, HTTPS, DHCP, RTP/RTSP, SMTP, NTP, UPnP, SNMP, SFTP
Web browser	IE10/11, Safari V12.1 above, Firefox V.52 above, Google chrome V.57 above, Edge V.79 above
Security	IP address filter; complicated password; Authenticated username and password
Streaming Method	Unicast/Multicast
Application Programming Interface	ONVIF (Profile S/G/T/M)

ELECTRICAL	
Input Voltage / Current	D12V/POE(IEEE802.3af)
Power Consumption (IR OFF)	2.5W-3.5W
(IR ON)	4.5W-6W

MECHANICAL	
Material	Metal
Dimensions (HxWxD)	150.8*70.9*70.9mm
Weight	400g

ENVIRONMENTAL	
Operating Conditions	-35~+60°C/less than ≤ 95% RH
Ingress Protection	IP 67
Certificate	CE,FCC,ROHS,BIS,ISO 9001,Essential Requirement (ER) by STQC

DIMENSION

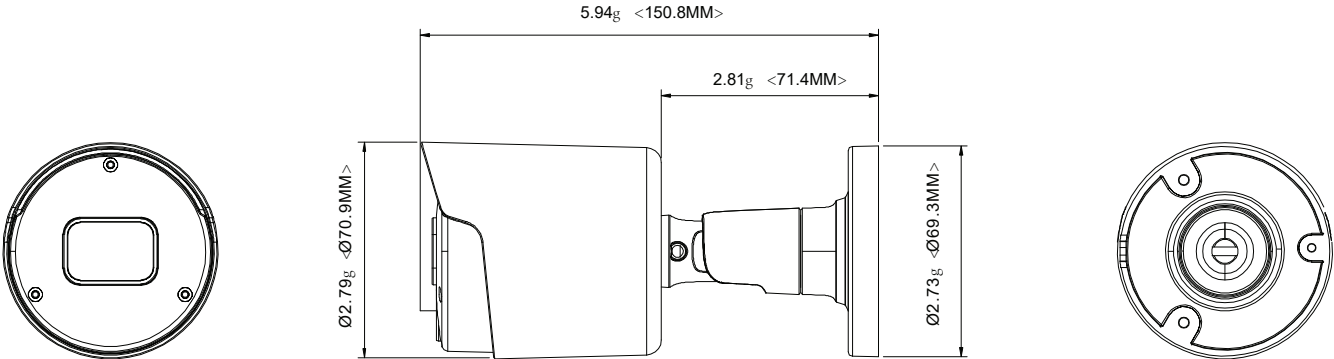

For more information,
www.honeywellbuildings.in
 Call: 000-8000-502167
 Email: enquiry.mms@honeywell.com

Honeywell HBT India Buildings
 Unitech Trade Center, 5th Floor, Sector-43,
 Block C, Sushant Lok Phase - I,
 Gurgaon - 122 002.

I-HIPB5PI-MF | 02 | 09/25
 © 2025 Honeywell International Inc.

